

# HullVac<sup>TM</sup>

## HV635 Single Stage Rotary Piston Vacuum Pump



### Why Upgrade Now?

#### Sealed Bearings

Bearing life is enhanced by isolating them from harmful process grit and solvents.

#### Tough Valve Assemblies

Heavy duty studs, springs and wear plates are mounted to hardened steel seats designed to prevent broken springs from falling into the pumping chamber.

#### Internal Sealing Fluid Channels

Sealing oil enters the pumping chambers through internal channels rather than exterior piping that is prone to damage and leakage.

#### Metal Belt Guards

Steel construction enhances safety and durability.

#### Oil Flow Indicator

An oil stream splashes onto the site port ensuring easy verification even when oil is opaque.

#### Redundant Shaft Seals

Triple Redundant Viton shaft seals ride on hardened steel sleeves to guard against leakage.

#### Caged Hinge Bars

One piece construction enhances wear life and reduces operating noise.

#### Large Site Port

Large diameter glass site port with stainless steel bezel and o-ring seal makes checking oil level and condition easy even when oil is opaque.

#### No Center Wall Bearing

Failures associated with lubricating a difficult to reach bearing are eliminated.

#### Low Vibration

Three chamber design provides exceptional balance. Pump operates with minimal vibration sitting on any flat surface while enhancing service life.

## The Next Generation

Get all the improvements in one durable, reliable, tough pump.

## HV635 Specifications

Free Air Displacement	635 CFM	Rotation Speed	555 RPM
Vacuum Stages	1	Oil Capacity	15 Gallons
Ultimate Pressure (trapped gauge)	0.008 Torr	Weight	2800 LBS
Ultimate Pressure Gas Ballast	0.100 Torr	Inlet Connection	6" Flange
Motor Power	30 HP	Outlet Connection	4" NPT
Voltage	208/230/460/575	Max Cooling Water 60 F	5 Gal/Min

### Dimensions

A	30.3	H	57.6
B	38.6	I	32.8
C	25.3	J	4.0" NPT
D	(4) – 0.94	K	17.9
E	32.9	L	2.6
F	26.8	M	6" ANSI
G	24.4		
All dimensions in inches.			

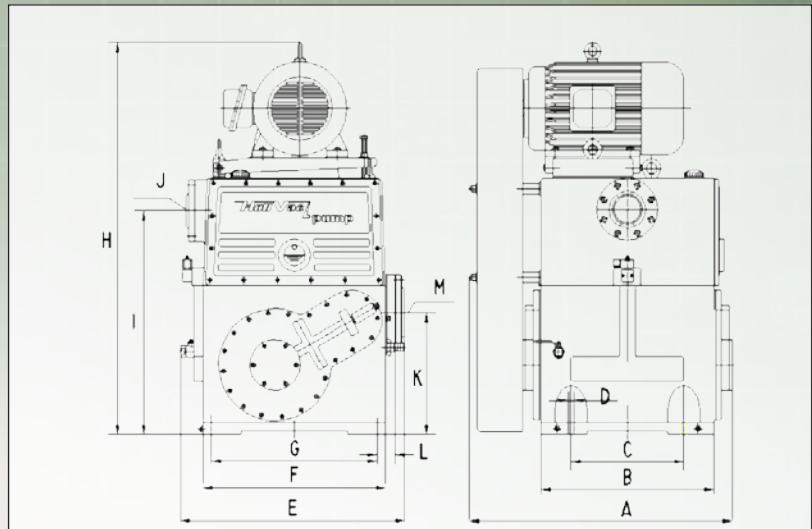

DEKKER, a privately-held, ISO 9001 certified company headquartered in Michigan City, Indiana, is one of the top vacuum equipment suppliers in the industry. DEKKER built its reputation with some of the most efficient and reliable products on the market, a staff known for its expertise, and a solutions-based approach to customer applications based on hundreds of installations.

  
**DEKKER**  
 VACUUM TECHNOLOGIES, INC.

888.925.5444 | dekkervacuum.com